

FA SERIES SPRING RETURN DAMPER ACTUATOR

2 Point Spring Return Control
20 Nm

FA...20S (S) SERIES

FA series Spring Return actuators are developed for general air damper application, rotary valve and other devices which require a fail-safe function. During normal operation, the actuator motorized the device. In the event of power outage, the actuator springs back to its original position.



PRODUCT FEATURE

- Torque 20 Nm
- Damper size 4.0 m²
- Power supply AC/DC 24V and AC 230 V
- Shaft dimensions - Ø 12...20 mm / □ 9...14 mm
- Minimum Shaft Length 90 mm
- Adjustable angle of rotation
- Selectable direction of rotation of reversing actuator
- Actuator with 1 m cable connection
- Optional 1 Fixed and 1 Adjustable SPDT auxiliary switches

MODEL SELECTION TABLE

MODEL/ TYPE	TORQUE	POWER SUPPLY	RUNNING TIME	AUXILIARY SWITCHES
FA 1-20	20 Nm	AC/DC 24 V ± 10%	50...70 sec (Spring Back <35 sec)	-
FA 1-20S	20 Nm	AC/DC 24 V ± 10%	50...70 sec (Spring Back <35 sec)	2 x SPDT (Fixed & Adjustable)
FA 2-20	20 Nm	AC 230 V ± 10%	50...70 sec (Spring Back <35 sec)	-
FA 2-20S	20 Nm	AC 230 V ± 10%	50...70 sec (Spring Back <35 sec)	2 x SPDT (Fixed & Adjustable)

DIMENSION (mm)

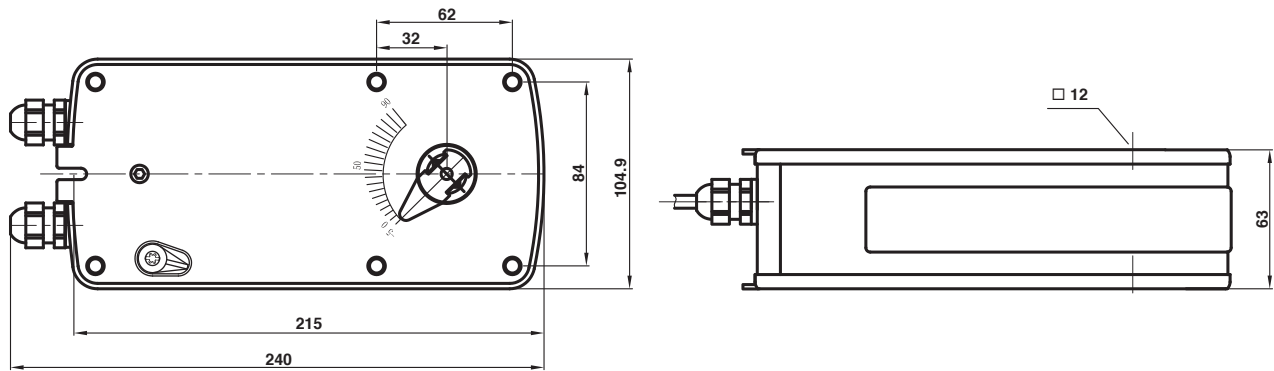

TECHNICAL SPECIFICATION

MODEL NUMBER	FA 1-20S (S)	FA 2-20S (S)
TORQUE	20 Nm	20 Nm
DAMPER SIZE	4.0 m ²	4.0 m ²
SHAFT DIMENSION	Ø 12...20 mm / □ 9...14 mm*	Ø 12...20 mm / □ 9...14 mm*
POWER SUPPLY	AC/DC 24 V ± 10%	AC 230 V ± 10%
FREQUENCY	50...60 Hz	50...60 Hz
CONTROL SIGNAL	2 point control	2 point control
POWER CONSUMPTION		
● OPERATING	12.0 W	12.0 W
● END POSITION	8.0 W	8.0 W
FOR WIRE SIZING	14.0 VA	14.0 VA
ELECTRICAL CONNECTION	1 m Cable	1 m Cable
AUXILIARY SWITCHES RATING	2 (1.5) A, AC 250 V	2 (1.5) A, AC 250 V
PROTECTION CLASS	Class III ⚡	Class II ⚡
ANGLE OF ROTATION	90° (95° mechanical)	90° (95° mechanical)
WEIGHT	2.8 Kg	2.8 Kg
LIFE CYCLE	60,000 Rotation	60,000 Rotation
SOUND LEVEL	75 dB	75 dB
IP PROTECTION	IP54	IP54
OPERATING TEMPERATURE	-30°...50° as per IEC 721-3-3	-30°...50° as per IEC 721-3-3
NON-OPERATING TEMPERATURE	-30°...+60° C / IEC 721-3-2	-30°...+60° C / IEC 721-3-2
AMBIENT HUMIDITY	5%...95% rH non condensing / EN	5%...95% rH non condensing / EN
MAINTENANCE	Maintenance Free	Maintenance Free
MODE OF OPERATION	Type I / EN 60730-1	Type I / EN 60730-1
EMC	CE & ISO 9000 EN / EEC	CE & ISO 9000 EN / EEC

*Note that shaft dimension has a tolerance offset of ± 0.2mm.

FA SERIES SPRING RETURN DAMPER ACTUATOR

2 Point Spring Return Control
20 Nm

WIRING DIAGRAM FA...20S (S) POWER SUPPLY AC/DC 24 OR AC 230V

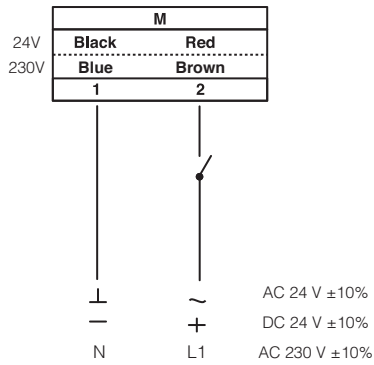

DIRECTION OF ROTATION FA...20S (S)

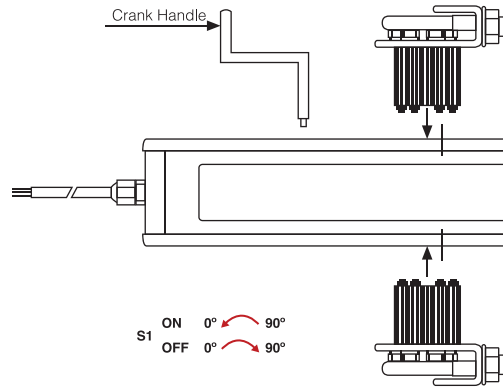

WIRING DIAGRAM FA...20S (S) AUXILIARY SWITCHES

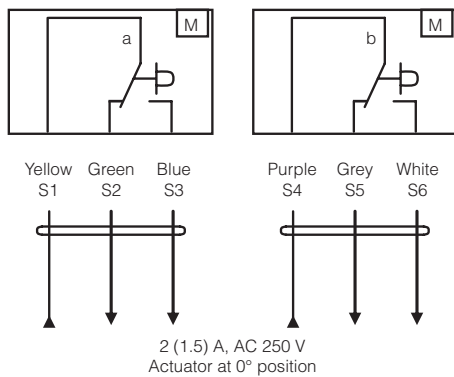

AUXILIARY SWITCH FA...20S (S)

Auxiliary switch **(a)** factory-fixed at 5°.

Auxiliary switch **(b)** can be optimally adjusted between 0°...90°.

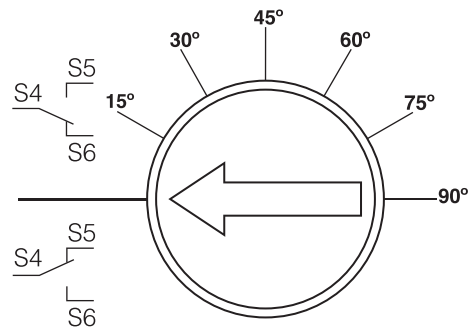

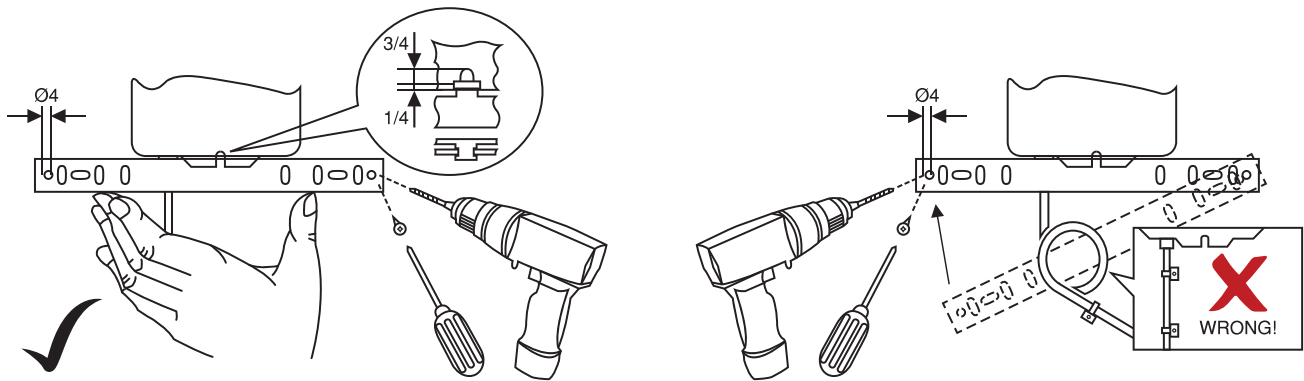

Switch **(a)** factory-fixed at 5°
Switch **(b)** adjustable 0°...90°

INSTALLATION / MOUNTING INSTRUCTION



IMPORTANT REMARK

For special requirement, consult your local Swisotec's representative.

  This actuator includes electrical and electronic components and may not be disposed as household garbage. Please consider the local valid legislation.

AC / DC 24 V: Connect via safety isolating transformer.
AC 230 V: To isolate from the main power supply, the system must incorporate a device which disconnects the phase conductor (with at least a 3mm contact gap.)

The performance specifications are nominal and conform to acceptable industry standards. Swisotec shall not be liable for damages resulting from misapplication or misuse of its products.